

THE ART OF LIGHTING

SINCE 1923



02	ABOUT US
03	COMPANY INFORMATION
04	THE ART OF JAPANESE CRAFTSMANSHIP
06	HISTORY
09	INDEX
12	FRANK LLOYD WRIGHT® COLLECTION
24	MAYUHANA®
30	JAKOBSSON LAMP
32	TWILIGHT
34	K-SERIES
36	TEAR DROP
38	SUI & SYOKU
40	RAI
42	CREA
44	FACTS & FIGURES
52	CONTACT

ABOUT US

For 100 years of creating a timeless design and the aesthetic quality of lighting with Japanese craftsmanship, YAMAGIWA has been manifesting beautiful living surroundings and unrivaled value to the society through “The Art of Lighting.”



COMPANY INFORMATION



YAMAGIWA TOKYO

3F Maruwa Bldg. 3-16-13 Shiba,
Minato-ku, Tokyo
105-0014 Japan

YAMAGIWA OSAKA

1F Oak Shinsaibashi Bldg. 3-5-8 Minamisemba,
Chuo-ku, Osaka-shi, Osaka
542-0081 Japan

YAMAGIWA NAGOYA

1-2F Maruwa Meieki Bldg. 4-23-9 Meieki,
Nakamura-ku, Nagoya-shi, Aichi
450-0002 Japan



The Art of Japanese Craftsmanship — Exquisite Lighting Rooted in Tradition



Japan has a rich tradition of craftsmanship—a philosophy that extends beyond aesthetics to a deep commitment to detail and quality that resonates with people. YAMAGIWA's lighting embodies this ethos, thoughtfully designed by architects and industrial designers and meticulously crafted by skilled artisans in Japan, whose expertise lends authenticity to each piece.

Bringing together traditional techniques such as woodcraft, metalwork, glasswork, and washi papermaking with modern technology, each piece is a fusion of heritage and innovation, radiating a beautiful glow. From the careful selection of materials to the final finishing touches, every stage is guided by uncompromising quality control, reflecting the pride and precision of "Made in Japan."



HISTORY



ESTABLISHMENT

Founded as a wholesale distributor of electrical materials in Akihabara, Tokyo.

1923



ESTABLISHED LIGHTING BUSINESS DEPARTMENT

Started import business with the partnership of European and American lighting companies.

In the same year, expanded domestic business targeting clientele in establishments such as museum, office, emporium and hotel.

In the late 1960, launched YAMAGIWA original collections.

1964



ESTABLISHED SUBSIDIARIES

(LD YAMAGIWA LAB., YAMAGIWA TEC., TL YAMAGIWA LAB.)

Established subsidiaries for lighting design and technology.

Introduced architectural lighting to Japan and produced numerous masterpieces with lighting designers from the lab.

1970

1954

ESTABLISHED LIGHTING DEPARTMENT

Started lighting business.



1966

CREATED COMPANY LOGO

Designed by Yusaku Kamekura, a Japanese modern graphic designer.



1983

OPENED LIVINA

Started retail business with opening LIVINA across Japan as shops and showrooms for consumers under the concept of "Living Art".



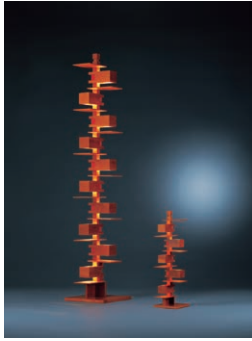

LICENSED WITH
THE FRANK LLOYD
WRIGHT
FOUNDATION

Started licensed partnership with the Frank Lloyd Wright Foundation. In 1994, started manufacturing and producing the Frank Lloyd Wright collection.

1992



MERGED WITH
THE MARUWA
GROUP

Merged with the MARUWA group to produce the lighting fixture with their specialty in the development of LED resources and light quality accordingly.

2013

CREATED
THE TAGLINE
“THE ART OF LIGHTING”
BASED ON OUR
NEW CORPORATE VISION

2020

100TH
ANNIVERSARY
OF YAMAGIWA

2023

2007

RELEASED
MAYUHANA®
DESIGNED BY
TOYO ITO

Released MAYUHANA® designed by Toyo Ito. YAMAGIWA has been producing collaboration items with over 70 designers and architects in the world since late 1960.



2014

REFINED
THE LOGO

Designed by Taku Satoh, a Japanese contemporary graphic designer.



yamagiwa

2023

EXHIBITED AT
MILAN DESIGN WEEK

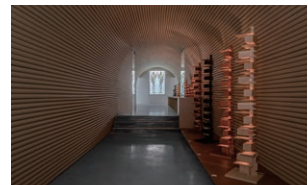

2024

EXHIBITED AT
MAISON & OBJET



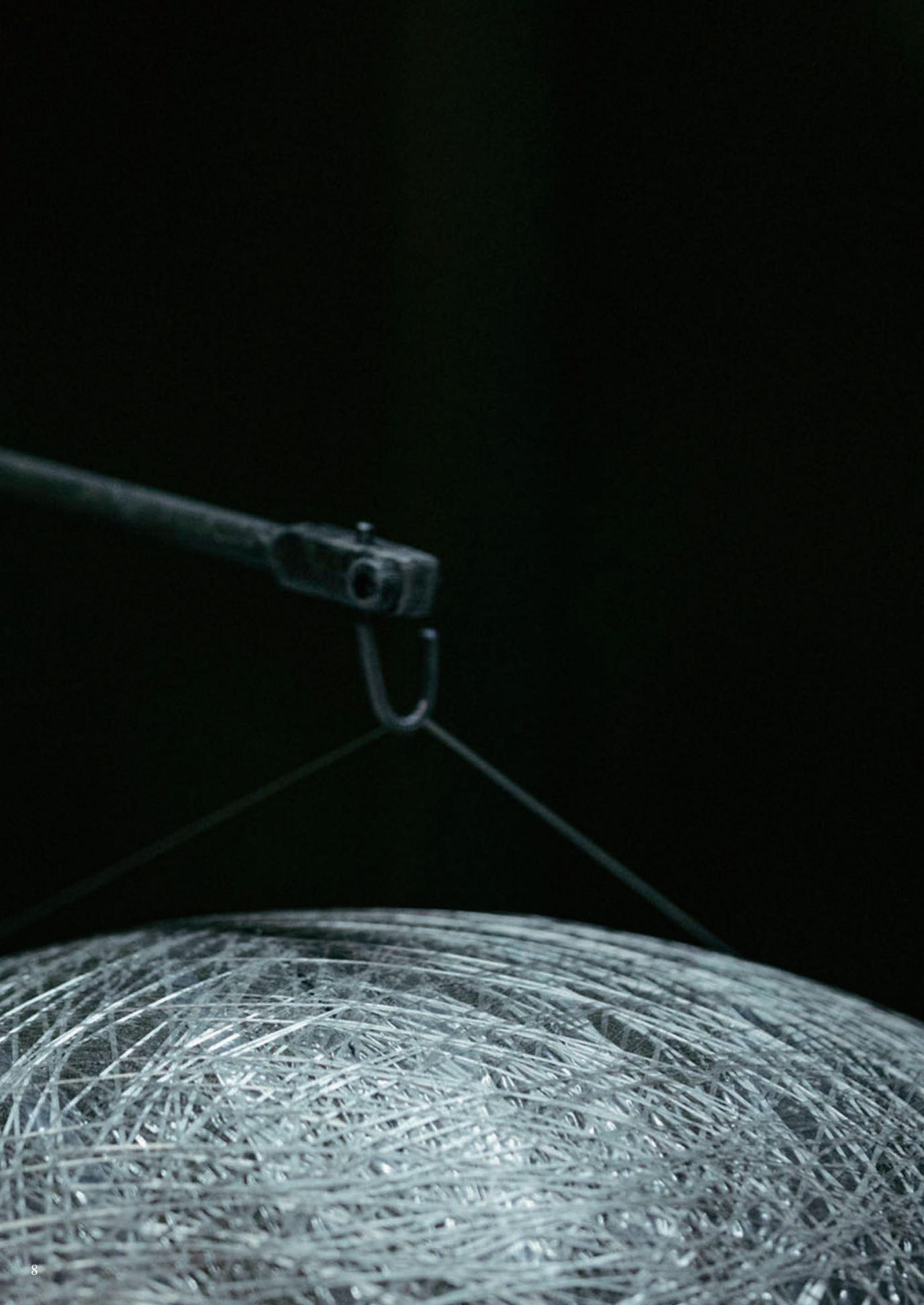

INDEX

FRANK LLOYD WRIGHT® COLLECTION



TALIESIN® 2
SE316: Cherry



TALIESIN® 2
SE317: Walnut



TALIESIN® 2
SE321: Black



TALIESIN® 2
SE330: Oak



TALIESIN® 3
SE309: Cherry



TALIESIN® 3
SE318: Walnut



TALIESIN® 3
SE322: Black



TALIESIN® 3
SE331: Oak



TALIESIN® 4
SE319: Cherry



TALIESIN® 4
SE320: Walnut



TALIESIN® 4
SE323: Black



TALIESIN® 4
SE332: Oak



TALIESIN® 1 FLOOR
SE311: Cherry



TALIESIN® 1 FLOOR
SE313: Walnut



TALIESIN® 1
SE310: Cherry



TALIESIN® 1
SE314: Walnut



TALIESIN® 1 MINI
SE312: Cherry



TALIESIN® 1 MINI
SE315: Walnut



TALIESIN® 2
WALL SCONCE
BE304: Cherry



TALIESIN® 2
WALL SCONCE
BE306: Walnut
*MOQ 12~24pcs



TALIESIN® 2
WALL SCONCE
BE308: Oak
*MOQ 12~24pcs

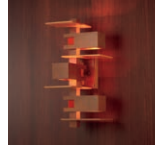

TALIESIN® 3
WALL SCONCE
BE305: Cherry



TALIESIN® 3
WALL SCONCE
BE307: Walnut



TALIESIN® 3
WALL SCONCE
BE309: Oak



TALIESIN® PENDANT 11
PE301: Cherry



TALIESIN® PENDANT 7
PE302: Cherry

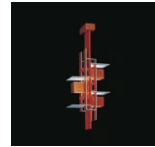

TALIESIN® PENDANT 3
PE303: Cherry



ROBIE® 1
BE302: Cherry

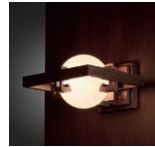

ROBIE® 1
BE303: Walnut



TALIESIN® POLYGON
SE329

MAYUHANA®



MAYUHANA®
GOBEN
SE118: Large



MAYUHANA®
GOBEN
SE119: Small



MAYUHANA®
MINI TABLE
SE181: φ190



MAYUHANA® MA
BLACK MINI TABLE
SE181B: φ190



MAYUHANA®
FLOOR
SE120: Mie Floor

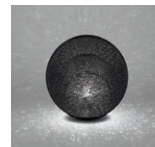

MAYUHANA®
MA BLACK FLOOR
SE161B: Mie Floor

INDEX

MAYUHANA®



MAYUHANA®
FLOOR
SE141: Oval Floor

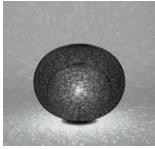

MAYUHANA®
MA BLACK FLOOR
SE163B: Oval Floor



MAYUHANA®
FLOOR
SE151: Sphere Floor

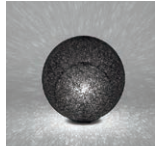

MAYUHANA®
MA BLACK FLOOR
SE164B: Sphere Floor



MAYUHANA®
YUGAMI
SE121

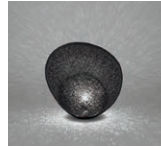

MAYUHANA®
MA BLACK YUGAMI
SE162B



MAYUHANA®
ARCH
SE144



MAYUHANA®
MA BLACK ARCH
SE167B



MAYUHANA®
TALL FLOOR
SE142



MAYUHANA® MA
BLACK TALL FLOOR
SE165B

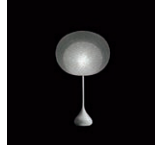

MAYUHANA®
SHORT FLOOR
SE143

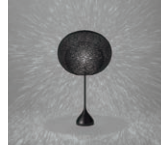

MAYUHANA® MA
BLACK SHORT FLOOR
SE166B



MAYUHANA®
PENDANT
PE101: Mie Pendant
φ500

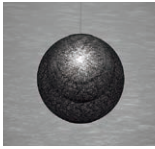

MAYUHANA®
MA BLACK PENDANT
PE121B: Mie Pendant
φ500

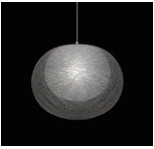

MAYUHANA®
TALL PENDANT
PE112: Oval Pendant
φ470

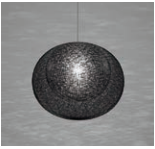

MAYUHANA®
MA BLACK PENDANT
PE122B: Oval Pendant
φ470

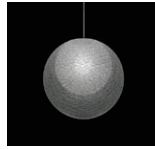

MAYUHANA®
PENDANT
PE119: Sphere Pendant
φ430

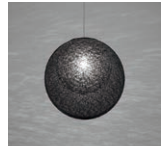

MAYUHANA®
PENDANT
PE123B: Sphere Pendant
φ430

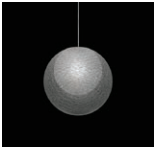

MAYUHANA®
PENDANT
PE124: Pendant
φ360



MAYUHANA®
MA BLACK PENDANT
PE124B: Pendant
φ360



MAYUHANA®
PENDANT
PE125: Mini Pendant
φ190

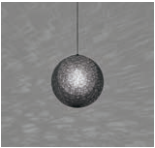

MAYUHANA®
MA BLACK PENDANT
PE125B: Mini Pendant
φ190

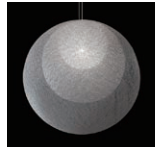

MAYUHANA®
GIANT
PE113: φ1100

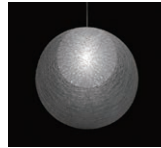

MAYUHANA®
GIANT
PE120: φ800

TWILIGHT



TWILIGHT
SE183K: Table



TWILIGHT
FE221K: Pendant
φ450



TWILIGHT
FE222K: Pendant
φ300

SUI



SUI
FE210: φ510



SUI
FE211: φ400



SUI
FE212: φ340

SYOKU



SYOKU
FE213: φ550



SYOKU
FE214: φ410

RAI



RAI
FE218: ϕ 750



RAI
FE219: ϕ 540



RAI
FE220: ϕ 400

JAKOBSSON LAMP



JAKOBSSON LAMP
SE168: ϕ 400



JAKOBSSON LAMP
SE169: ϕ 360



JAKOBSSON LAMP
SE170: ϕ 260



JAKOBSSON LAMP
FE205: ϕ 540



JAKOBSSON LAMP
FE206: ϕ 440

K-SERIES



K-SERIES
SE171

TEAR DROP



TEAR DROP MINI LED
SE172

CREA



CREA
FE215: Ebony



CREA
FE216: Walnut



CREA
FE217: Oak

FRANK LLOYD WRIGHT® COLLECTION



Designed by FRANK LLOYD WRIGHT

This collection includes representations of the original masterpieces of legendary architect, Frank Lloyd Wright. Frank Lloyd Wright licensed products represent refined style, through the expression of the integral relationships between the natural and the manmade, and between material and design.

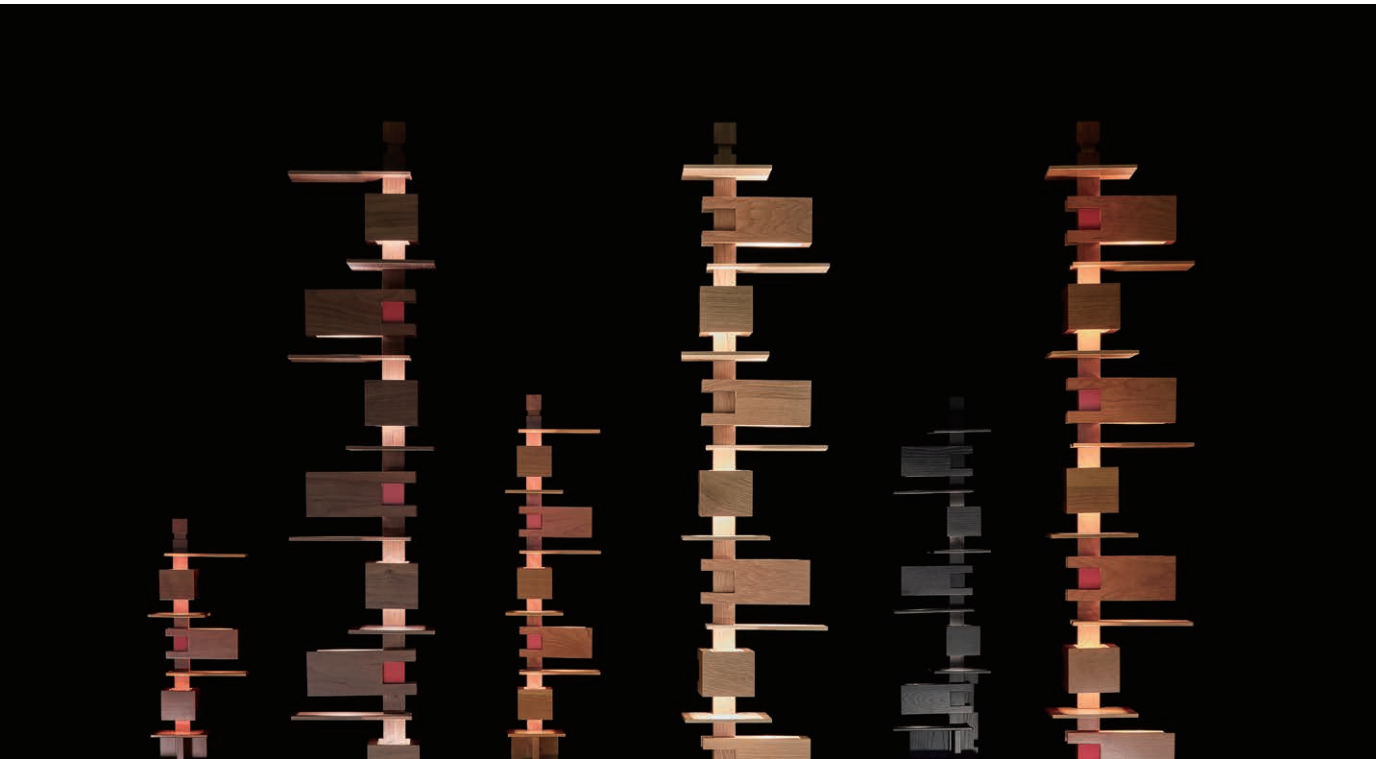

Designer

FRANK LLOYD WRIGHT

Frank Lloyd Wright (1867-1959) is one of the most legendary figures in American architecture of the twentieth century. He was recognized in 1991 by the American Institute of Architects as “the greatest American architect of all time.” He designed more than 1,000 structures in his 70 year career. His masterpieces, “Fallingwater” and “Guggenheim Museum” have been designated UNESCO World Heritage Sites. As he is known for coining the term “organic architecture,” he established his architectural style, believing that architecture should be at home in nature.

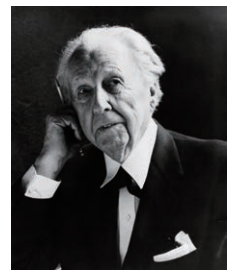

OBMA ©FLWright Fdn.



TALIESIN® 2 OAK (SE330)

www.areastore.com | Photography: João Guimarães



TALIESIN® 2

This series embodies the timeless mastery of Frank Lloyd Wright. Crafted in collaboration with Japanese artisans, YAMAGIWA is the only brand outside North America authorized by the Frank Lloyd Wright Foundation to reissue these iconic designs.



The Frank Lloyd Wright Foundation Archives (The Museum of Modern Art | Avery Architectural & Fine Arts Library, Columbia University, New York). All Rights Reserved.



TALIESIN® 2 WALNUT <SE317>

JYUGAKUEN MYONICHIKAN



TALIESIN® 2 CHERRY <SE316> / TALIESIN® 3 CHERRY <SE309>

NIWA KAMAKURA

TALIESIN® 3



TALIESIN® 3 BLACK <SE322>

TALIESIN® 4



TALIESIN® 4 CHERRY <SE319>

Inspired by the natural effects of light in nature, he believed the sun and moonlight that filters through leaves and branches to be beautiful; this has now been captured in the TALIESIN® series.

It is composed of a series of illuminated rectangular, solid wood boxes to create an organic sculptural composition to this floor lamp. It provides soft, patterned, indirect illumination while concealing the light sources and reducing glare. The series functions as complementary interior decor both during the day and at night.



TALIESIN® 3 CHERRY <SE309>

NIWA KAMAKURA



TALIESIN® WALL SCONCE

Inspired by a pendant lamp designed by Frank Lloyd Wright in 1933, when he converted the Hillside Home School gymnasium into a theater, the TALIESIN® WALL SCONCE embodies his masterful approach to lighting. The interplay of multiple wooden blocks controls the upward and downward illumination, while the light reflects off the shades, creating a warm and inviting atmosphere.



TALIESIN® 3 WALL SCONCE CHERRY <BE305>

NIWA KAMAKURA



TALIESIN® 2 WALL SCONCE WALNUT <BE306>



TALIESIN® 3 WALL SCONCE OAK <BE309>



TALIESIN® | FLOOR

JIYUGAKUEN MYONICHIKAN

TALIESIN® 1

TALIESIN® 1 is designed for Wright's summer home in Taliesin, Spring Green, Wisconsin. One of his architectural forms, the square roof, is incorporated into the design making it appear as if there is another small building in a home. It gives off comfort with its warm light from the wood.

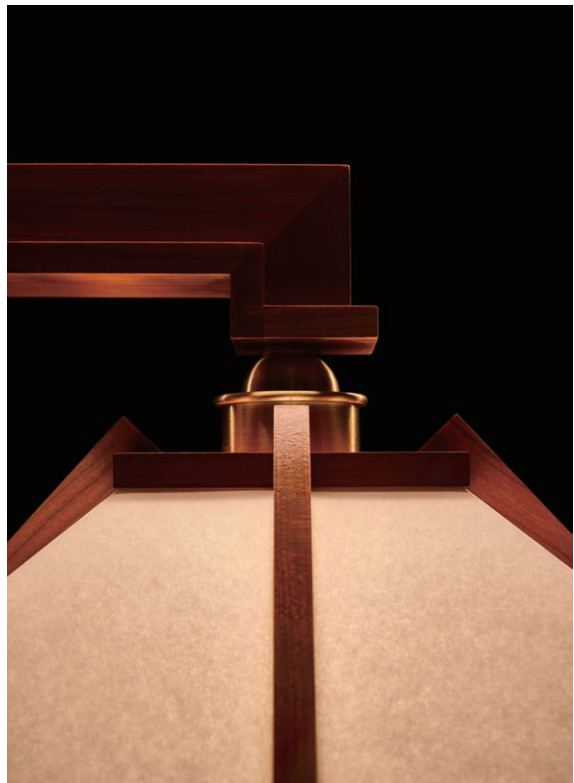

TALIESIN® | CHERRY <SE310>



ROBIE® 1 CHERRY <BE302>

ROBIE® 1

A wall sconce designed for the living room of the Frederik Robie House (Chicago, 1908). The house is representative of the prairie house of Wright's early architectural style that emerged in Chicago around 1900. The sphere glass globe appears to be floating inside of the wooden circle frames. ROBIE® allows the space to recreate Wright's original design concept.



ROBIE® 1 WALNUT <BE303>



TALIESIN® PENDANT 7 <PE302>

TALIESIN® PENDANT

This geometric motif pendant, an original design of TALIESIN® 2, was designed for the renovation of the original gymnasium of Wright's Hillside home school (1902) into a theatre in 1933. It is well designed and reduces glare without the use of glass or fabric shades, but employs wooden boxes and plywood shields to be suspended from the tall ceiling.

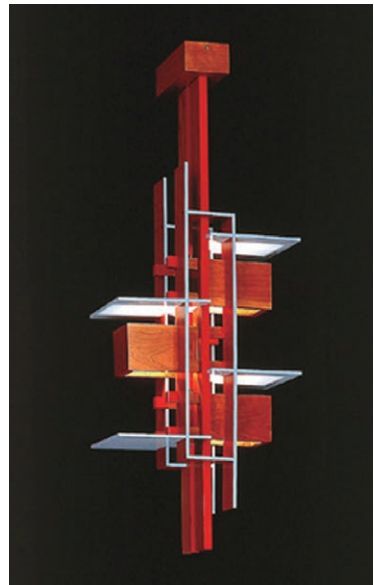

TALIESIN® PENDANT 3 <PE303>

TALIESIN® POLYGON

Designed by TOYO ITO

This is one of the series in the 'TALIESIN® Special Limited Model homage to Frank Lloyd Wright' collection, introduced in 2018. While using TALIESIN® 2 as the prototype, Ito created the new TALIESIN® by reinterpreting Wright's ideas and motifs in architecture from his own perspective.



TALIESIN® POLYGON <SE329>

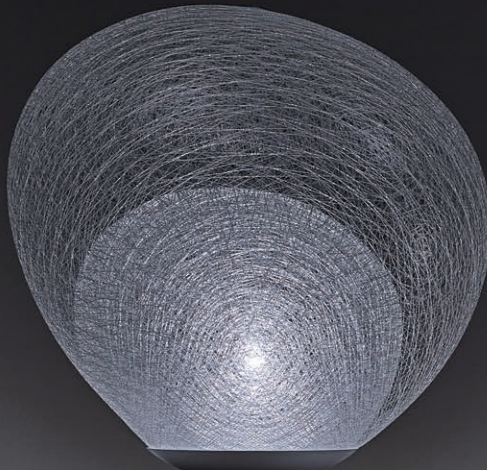
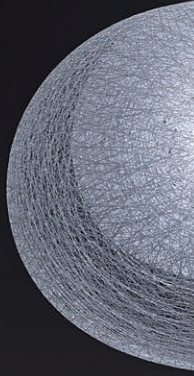
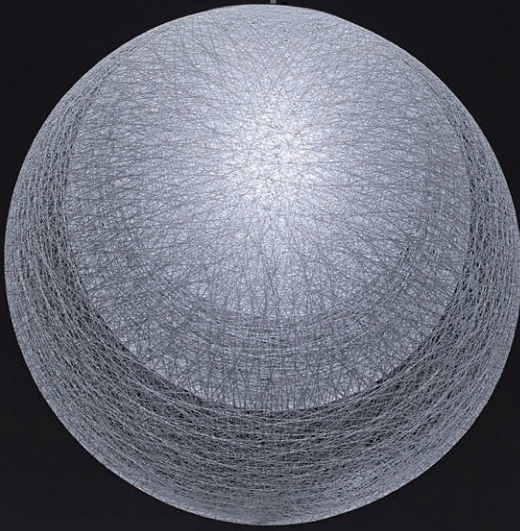

Photo: FUJITSUKA Mitsumasa

Designer

TOYO ITO

A world-renowned Japanese architect who won the Pritzker Architecture Prize in 2013 and is known for his innovative and conceptual designs. His most representative projects include Sendai Mediatheque (Japan, 2000), Serpentine Gallery Pavilion (UK, 2002), Torres Porta Fira (Spain, 2010), and National Taichung Theater (Taiwan R.O.C., 2016).





MAYUHANA®

Designed by TOYO ITO

The spun thread design of this delicate, fiberglass creation is reminiscent of a cocoon. It lets out a soft light that is enhanced by the double and triple shells. This is designed by world-renowned Japanese architect, Toyo Ito. The MAYUHANA® includes pendant, floor, and table lamps with a variety of shapes available in two colors.



MAYUHANA® YUGAMI <SEI21>

NIWA KAMAKURA

The soft light, reminiscent of the traditional Japanese paper lanterns known as Bombori, brings airy elegance. Similar to how a thread is spun off a cocoon, MAYUHANA® is made by minding string around a mold. Each one is handmade by Japanese craftsmen.



MAYUHANA® GOBEN <SEI 18>



Photo: FUJITSUKA Mitsumasa

Designer

TOYO ITO

A world-renowned Japanese architect who won the Pritzker Architecture Prize in 2013 and is known for his innovative and conceptual designs. His most representative projects include Sendai Mediatheque (Japan, 2000), Serpentine Gallery Pavilion (UK, 2002), Torres Porta Fira (Spain, 2010), and National Taichung Theater (Taiwan R.O.C., 2016).



MAYUHANA® GIANT <PE120> / MAYUHANA® MIE PENDANT <PE101>



MAYUHANA® TALL FLOOR <SE142> / MAYUHANA® MIE PENDANT <PE101>

NIWA KAMAKURA

MAYUHANA®
MA BLACK



Styling: MITSUKO KURODA / Photo: MASAOKI INOUE

MAYUHANA® MA BLACK MIE PENDANT <PE121B>



MAYUHANA® MA BLACK MINI TABLE <SE181B>



JAKOBSSON LAMP <FE205>

Styling: MITSUKO KURODA / Photo: MASAAKI INOUE

JAKOBSSON LAMP

Designed by HANS-AGNE JAKOBSSON

JAKOBSSON LAMP brings out the full potential of ingredients of pine wood and has lit up Scandinavian living for a long time as a representative of Swedish designer, Hans-Agne Jakobsson. The soft light casted through the pine wood shades is reminiscent of a bonfire.





JAKOBSSON LAMP <SEI 69>

It is made of thinly sliced pine wood that has been slowly and naturally dried for a long time. The pine, which is grown in the harsh cold environment of Europe, has a beautiful surface thanks to the slow annual growth rings. JAKOBSSON LAMP, a Scandinavian masterpiece, has been faithfully reproduced by Japanese craftsmanship since 1997 under license from Jakobsson.

Designer

HANS-AGNE JAKOBSSON

Hans-Agne Jakobsson (1919-2009), a Swedish interior and furniture designer, born in Gotland, Sweden, is known for his glare-free lighting fixtures inspired by the idea of “Organic Modern” of Poul Henningsen and Alvar Aalto. He started designing at the age of 18 and later, he graduated as an architect in Göteborg. He began as an assistant to Carl Malmsten and Werner West known as the master of interior design. After he gained experience as a designer in several companies including General Motors, he founded his own lighting company “Hans-Agne Jakobsson AB” in Markaryd and started manufacturing light fixtures and furniture with his own design.

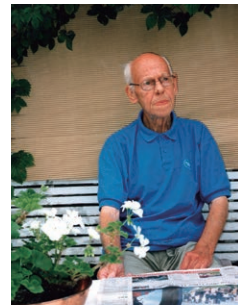

TWILIGHT

Designed by YAMAGIWA

TWILIGHT is an exquisitely designed lighting series inspired by the twilight sky, where the sun gracefully sets below the horizon. The light diffuses through the shade, meticulously crafted from glass fibers, imparting a radiant brilliance reminiscent of a crystal chandelier and evoking the warm hues of a sunset.



TWILIGHT <FE221K> / TWILIGHT TABLE <SE183K>

The opulent sparkle not only adds a touch of luxury to the space but also lends an air of sophistication, making it the perfect choice for those seeking elegance and refinement. With a rich variety that includes pendant, table, and floor lamps, The TWILIGHT series offers diverse options for comprehensive coordination.

TWILIGHT



TWILIGHT <FE221K>

K-SERIES

Designed by SHIRO KURAMATA

The masterpiece, K-SERIES epitomizes Japanese post modernism designed in 1972 by Shiro Kuramata, the Japanese legendary interior designer. By four Japanese craftsmen, it is made of draping a heated single piece of an acrylic sheet over a pole at same time, allowing it to hang naturally and harden. The opalescent acrylate resin of the exquisite smooth skewed surface generates a gradient glow and radiates with playfulness through the illusion of floating. Nebulous yet its unforgettable icon grabs your heart.



K-SERIES (SE171)



K-SERIES <SE171>

NIWA KAMAKURA

*Designer***SHIRO KURAMATA**

Shiro Kuramata (1934-1991) is a prolific Japanese interior designer who had seen potential in the latest science and technology since the '60s and created a number of innovative modern products. After studying interior design at Kuwasawa Design school, he founded the Kuramata Design Office in Tokyo in 1965. He frequently employed industrial materials such as acrylic, glass, aluminum, and steel mesh while combining them into traditional Japanese aesthetics for his works. Many of his works were created under the theme of "be free of gravity", which are transparent and floating like objects adapting to daily life. K-SERIES is one of the works that thoroughly reflects his philosophy.



TEAR DROP

Designed by TOKUJIN YOSHIOKA

An orb of light floats within the transparent solid glass globe of the teardrop. Scaled to the size of a human heart, it is not a lighting fixture, but a design of light. With this sophisticated design, TEAR DROP is selected as part of the permanent collection of the Museum of Modern Art (MoMA) in New York. One of the most notable features of its specification is the hard glass that is beautifully shaped like a pearl which is handmade by Japanese craftsmen. Not only does it provide soft light with less glare with sandblasting inside, but it also produces mystical light that does not have the material element of light source feel. It reaches your heart through a simple shape once lit up.



TEAR DROP MINI LED <SE172>



TEAR DROP MINI LED (SEI172)

PHOTO: Masaaki Inoue / BOUILLON

Designer

TOKUJIN YOSHIOKA

Tokujin Yoshioka (1967-) is a Japanese designer and artist, and established his own design company in 2000 after studying under the Japanese renowned designers Shiro Kuramata and Issei Miyake. Active in the fields of design, architecture and contemporary art, he is highly acclaimed globally. His latest masterpiece include the Sakura Torch for the Tokyo 2020 Olympic and Paralympic Games. He has won many international awards, and many of his works are chosen as part of permanent collections in world renowned museums, including the Museum of Modern Art (MoMA) and the Musée National d'Art Moderne. He was selected by Newsweek magazine as one of the 100 Most Respected Japanese in the World.

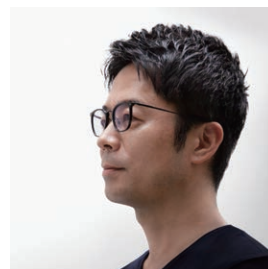

SUI & SYOKU

Designed by YAMAGIWA

SUI and SYOKU represent a contemporary reinterpretation of the traditional Japanese paper lanterns handcrafted with washi paper. Emitting a soft and comforting glow, the warm light diffuses beautifully through the washi shade.



SUI <FE210 / FE211 / FE212>

SUI

The SUI variation, shaped like a droplet, offers versatility in hanging options with its multiple available sizes.



SYOKU (FE213 / FE214)

SYOKU

The SYOKU design showcases a distinctive silhouette, with a recessed waistline that echoes the elegance of traditional spherical lanterns.

RAI

Designed by YAMAGIWA

Inspired by the form of a bud, the “Rai” was designed as a new standard for modern lanterns.

The shade is crafted from Mino Washi, one of Japan’s three most renowned traditional papers, and handmade by skilled artisans.

Its contemporary silhouette, combined with the soft glow through the Washi, creates a warm and inviting ambiance in various settings. The pendant comes in three sizes: large, medium, and small.



RAI <FE218>



RAI <FE218>



Mino Washi, recognized as one of the world's three great traditional papers, has a history spanning over 1,300 years. Known for its delicate texture and strength, it has long been used in traditional Japanese crafts such as wagasa (Japanese umbrellas) and shoji (paper sliding doors).

CREA

Designed by YAMAGIWA

CREA features a minimalist cylinder and a combination of wood and metal. Within its sophisticated simple slender design, the gentle light shining out of the slit brings elegance to the atmosphere. The Tamo ash, which has been used for furniture and flooring for a long time in Japanese history, matches a wide variety of interior design styles. Combining with metal makes it unique and special. It dramatically provides sufficient direct light with perfect distribution over dining tables and kitchen counters, with single fittings or multiple configurations.



CREA OAK <FE217>

CREA

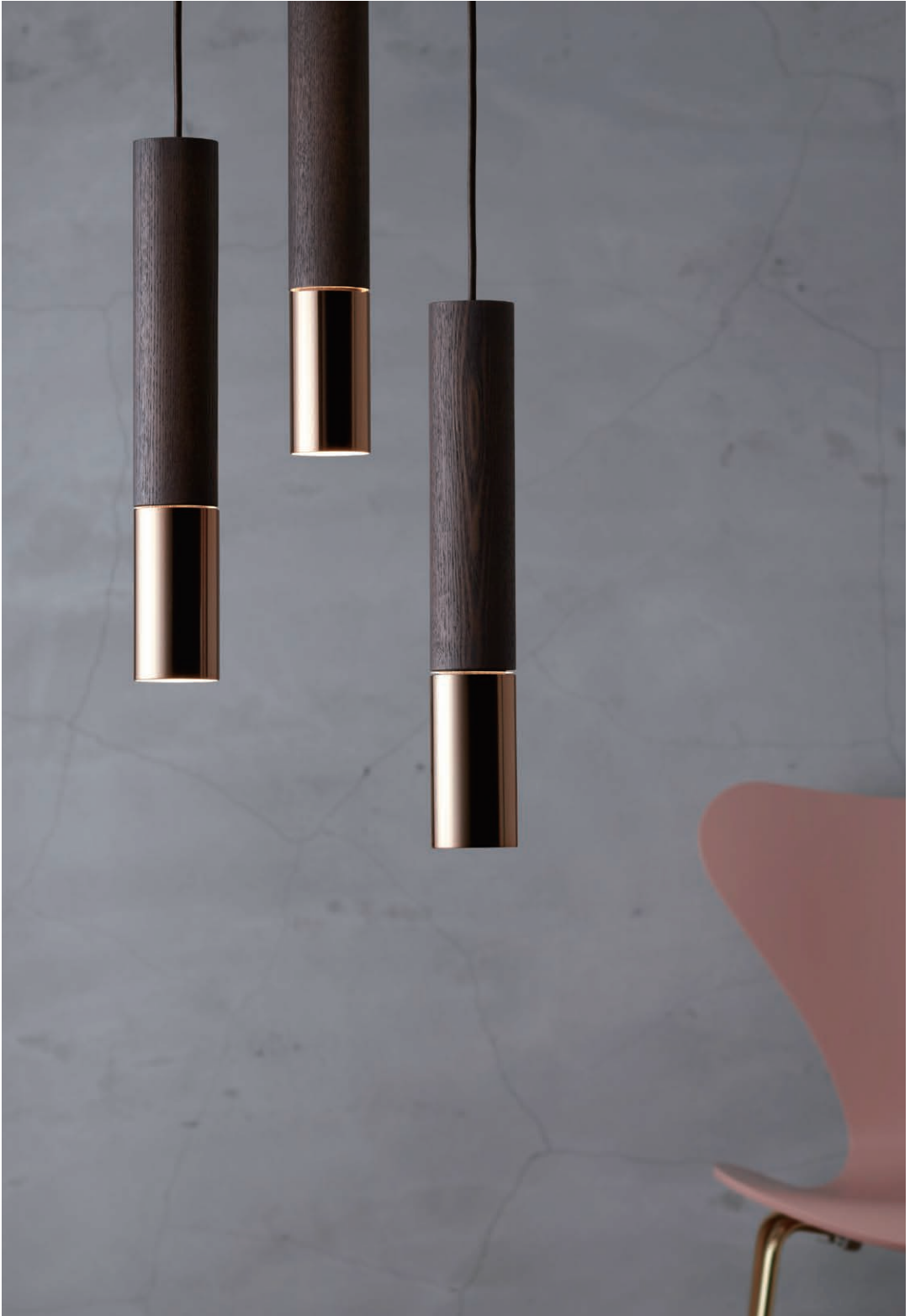

CREA EBONY <FE215>

FRANK LLOYD WRIGHT® COLLECTION

FLOOR

TALIESIN® 2

CE 220V-240V
SE316 Cherry
SE317 Walnut
SE321 Black
SE330 Oak
E14 Incandescent Bulb 25Wx10
(E14 LED Bulb 2.2Wx10)

PS E 100V
322S7263 Cherry
322S7264 Walnut
322S7347 Black
322S7501 Oak
E17 Incandescent lamp 25Wx10

20.0kg Cherry/Walnut/Oak
16.0kg Black

TABLE

TALIESIN® 3

CE 220V-240V
SE309 Cherry
SE318 Walnut
SE322 Black
SE331 Oak
E14 Incandescent Bulb 15Wx5
(E14 LED Bulb 1.7Wx5)

PS E 100V
322S2311 Cherry
322S7265 Walnut
322S7348 Black
322S7502 Oak
E12 Incandescent lamp 10Wx5

TABLE

TALIESIN® 4

CE 220V-240V
SE319 Cherry
SE320 Walnut
SE323 Black
SE332 Oak
E14 Incandescent Bulb 15Wx3
(E14 LED Bulb 1.7Wx3)

PS E 100V
322S7316 Cherry
322S7317 Walnut
322S7349 Black
322S7503 Oak
E12 Incandescent lamp 10Wx3

2255
1670
1087
4.0kg PE303
10.0kg PE302
16.0kg PE301
420 (x205)
420 (x205)
420 (x205)

SUSPENSION

TALIESIN® PENDANT

CE 220V-240V
PE301 Cherry
E14 LED Bulb 4Wx11
PE302 Cherry
E14 LED Bulb 4Wx7
PE303 Cherry
E14 LED Bulb 4Wx3

PS E 100V
322P2429 Cherry
E17 Incandescent lamp 25Wx11
322P2431 Cherry
E17 Incandescent lamp 25Wx7
322P2679 Cherry
E17 Incandescent lamp 25Wx3

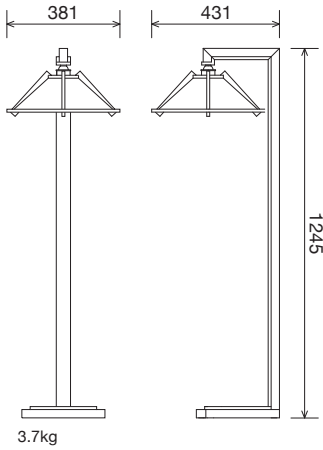

FLOOR

TALIESIN® I FLOOR

CE 220V-240V
SE311 Cherry
SE313 Walnut
E27 LED Bulb 8Wx1

PS E 100V
322S7562 Cherry
322S7564 Walnut
E26 Incandescent lamp 60Wx1

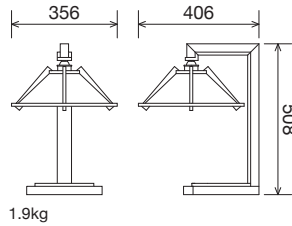

1.9kg

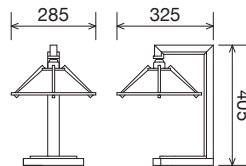

1.0kg

TABLE

TALIESIN® I

CE 220V-240V
SE310 Cherry
SE314 Walnut
E27 LED Bulb 8Wx1

PS E 100V
322S7563 Cherry
322S7565 Walnut
E26 Incandescent lamp 60Wx1

TABLE

TALIESIN® I MINI

CE 220V-240V
SE312 Cherry
SE315 Walnut
E14 LED Bulb 8Wx1

PS E 100V
322S2527 Cherry
322S7314 Walnut
E17 Incandescent lamp 60Wx1

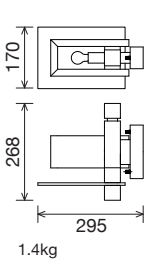

WALL

TALIESIN® 2 WALL SCNCE

CE 220V-240V
BE304 Cherry
BE306 Walnut
BE308 Oak
E14 LED Bulb 2.2Wx1
BE306/BE308 : *MOQ 12~24pcs

PS E 100V
322B2703 Cherry
322B2723 Walnut
322B2720 Oak
E17 Incandescent lamp 25Wx1

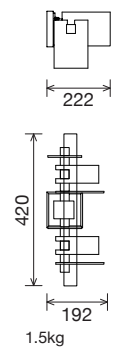

WALL

TALIESIN® 3 WALL SCNCE

CE 220V-240V
BE305 Cherry
BE307 Walnut
BE309 Oak
E14 LED Bulb 1.7Wx3

PS E 100V
322B2704 Cherry
322B2724 Walnut
322B2721 Oak
E12 Incandescent lamp 10Wx3

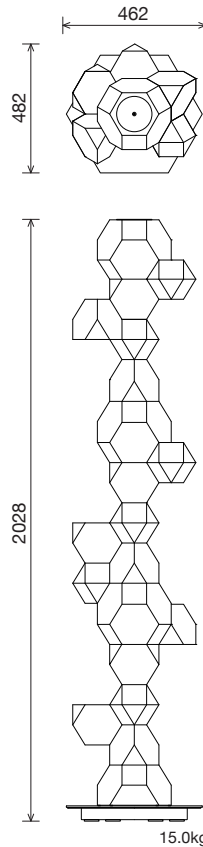

WALL

ROBIE® I

CE 220V-240V
BE302 Cherry
BE303 Walnut
E14 LED Bulb 6.5Wx1

PS E 100V
322B2325 Cherry
322B2691 Walnut
E17 Incandescent lamp 40Wx1

FLOOR

TALIESIN® POLYGON

CE 220V-240V
SE329
LED module 37.6W

PS E 100-240V
322S7433
LED module 54.7W

MAYUHANA®

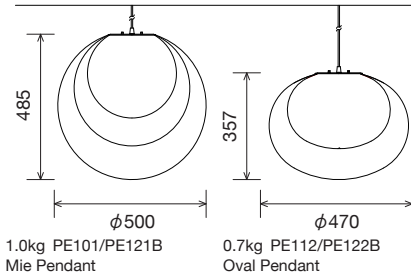

1.0kg PE101/PE121B
Mie Pendant

0.7kg PE112/PE122B
Oval Pendant

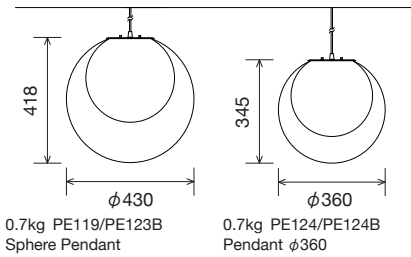

0.7kg PE119/PE123B
Sphere Pendant

0.7kg PE124/PE124B
Pendant 360

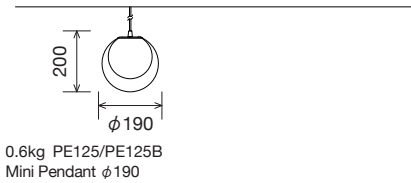

0.6kg PE125/PE125B
Mini Pendant 190

SUSPENSION

MAYUHANA®
PENDANT



- 220V-240V
- PE101 Mie Pendant ϕ 500
- PE112 Oval Pendant ϕ 470
- PE119 Sphere Pendant ϕ 430
- E27 LED Bulb 13Wx1
- PE124 Pendant ϕ 360
- E27 LED Bulb 8Wx1
- PE125 Mini Pendant ϕ 190
- E14 LED Bulb 5Wx1



- 100V
- 321P2909W Mie Pendantt ϕ 500
- 321P2912W Oval Pendant ϕ 470
- 321P2910B Sphere Pendant ϕ 430
- E26 Globe White bulb 100Wx1
- 321P2911W Pendant ϕ 360
- E26 Globe White bulb 95mm 60Wx1
- 321P2948W Mini Pendant ϕ 190
- E17 Incandescent lamp 40Wx1

SUSPENSION

MAYUHANA®
MA BLACK PENDANT



- 220V-240V
- PE121B Mie Pendant ϕ 500
- PE122B Oval Pendant ϕ 470
- PE123B Sphere Pendant ϕ 430
- E27 LED Bulb 13Wx1
- PE124B Pendant ϕ 360
- E27 LED Bulb 8Wx1
- PE125B Mini Pendant ϕ 190
- E14 LED Bulb 5Wx1



- 100V
- 321P2909B Mie Pendant ϕ 500
- 321P2912B Oval Pendant ϕ 470
- 321P2910B Sphere Pendant ϕ 430
- E26 Globe White bulb 95mm 100Wx1
- 321P2911B Pendant ϕ 360
- E26 Globe White bulb 95mm 60Wx1
- 321P2948B Mini Pendant ϕ 190
- E17 Incandescent lamp 40Wx1

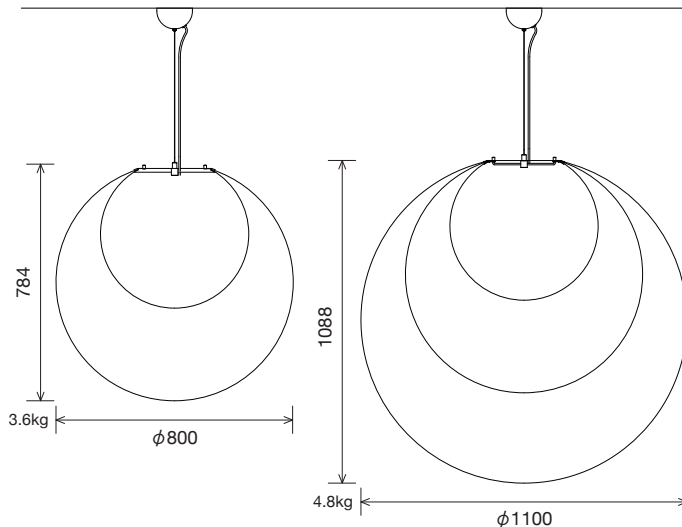

3.6kg

ϕ 800

1088

4.8kg

ϕ 1100

SUSPENSION

MAYUHANA® GIANT



- 220V-240V
- PE120 ϕ 800
- PE113 ϕ 1100
- E27 LED Bulb 18Wx1



- 100V
- 321P2868 ϕ 800
- 321P2867 ϕ 1100
- E26 Halogen lamp Energy Saver 150Wx1

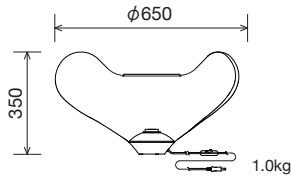
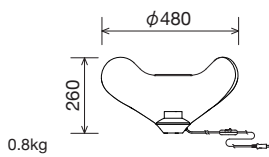

FLOOR

MAYUHANA® GOBEN

- CE** 220V-240V
SE118 Large ϕ 650
E27 LED Mirror Bulb 13Wx1
- SE119 Small ϕ 480
E27 LED Mirror Bulb 8Wx1

- PS E** 100V
321S7083 Large ϕ 650
E26 Bowl Mirror lamp 100Wx1
- 321S7084 Small ϕ 480
E26 Bowl Mirror lamp 60Wx1

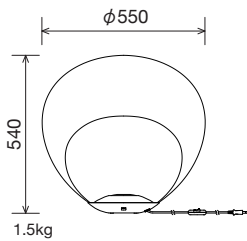

FLOOR

MAYUHANA® YUGAMI

- CE** 220V-240V
SE121
E27 LED Bulb 8Wx1

- PS E** 100V
321S7401W
E26 Globe Clear bulb 95mm 60Wx1

FLOOR

MAYUHANA® MA BLACK YUGAMI

- CE** 220V-240V
SE162B
E27 LED Bulb 8Wx1

- PS E** 100V
321S7401B
E26 Globe Clear bulb 95mm 60Wx1

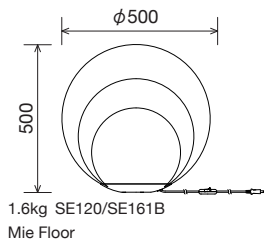

FLOOR

MAYUHANA® FLOOR

- CE** 220V-240V
SE120 Mie Floor
SE141 Oval Floor
SE151 Sphere Floor
E27 LED Bulb 8Wx1

- PS E** 100V
321S7400W Mie Floor
321S7402W Oval Floor
321S7403W Sphere Floor
E26 Globe White bulb 95mm 60Wx1

FLOOR

MAYUHANA® MA BLACK FLOOR

- CE** 220V-240V
SE161B Mie Floor
SE163B Oval Floor
SE164B Sphere Floor
E27 LED Bulb 8Wx1

- PS E** 100V
321S7400B Mie Floor
321S7402B Oval Floor
321S7403B Sphere Floor
E26 Globe Clear bulb 95mm 60Wx1

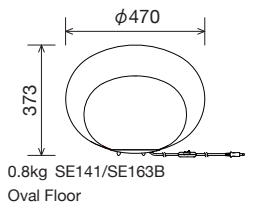

TABLE

MAYUHANA® MINI TABLE

- CE** 220V-240V
SE181 mini Table ϕ 190
E14 LED Bulb 5Wx1

- PS E** 100V
321S7506W mini Table ϕ 190
E17 Incandescent lamp 25Wx1

TABLE

MAYUHANA® MA BLACK MINI TABLE

- CE** 220V-240V
SE181B mini Table ϕ 190
E14 LED Bulb 5Wx1

- PS E** 100V
321S7506B mini Table ϕ 190
E17 Incandescent lamp 25Wx1

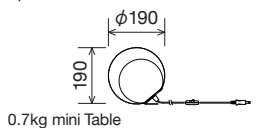
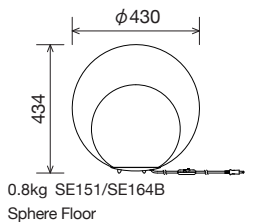

MAYUHANA®

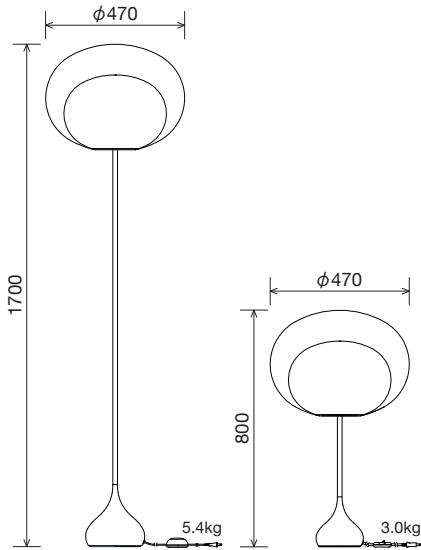

FLOOR

MAYUHANA® TALL FLOOR

CE 220V-240V
SE142
E27 LED Bulb 8Wx1

PS 100V
E 321S7404W
E26 Globe White bulb 95mm 60Wx1

MAYUHANA® MA BLACK TALL FLOOR

CE 220V-240V
SE165B
E27 LED Bulb 8Wx1

PS 100V
E 321S7404B
E26 Globe Clear bulb 95mm 60Wx1

FLOOR

MAYUHANA® SHORT FLOOR

CE 220V-240V
SE143
E27 LED Bulb 8Wx1

PS 100V
E 321S7405W
E26 Globe White bulb 95mm 60Wx1

MAYUHANA® MA BLACK SHORT FLOOR

CE 220V-240V
SE166B
E27 LED Bulb 8Wx1

PS 100V
E 321S7405B
E26 Globe Clear bulb 95mm 60Wx1

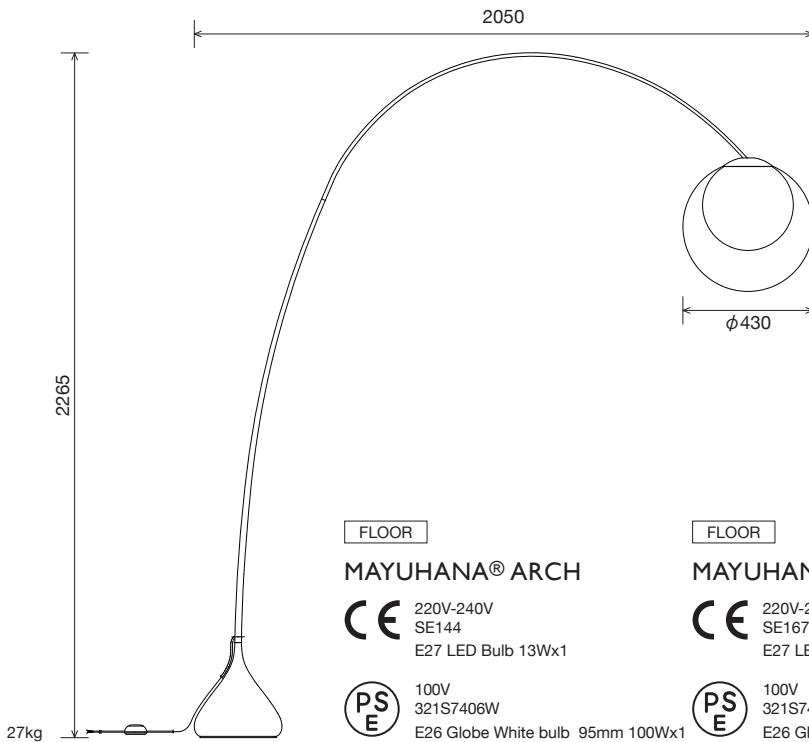

FLOOR

MAYUHANA® ARCH

CE 220V-240V
SE144
E27 LED Bulb 13Wx1

PS 100V
E 321S7406W
E26 Globe White bulb 95mm 100Wx1

FLOOR

MAYUHANA® MA BLACK ARCH

CE 220V-240V
SE167B
E27 LED Bulb 13Wx1

PS 100V
E 321S7406B
E26 Globe Clear bulb 95mm 60Wx1

JAKOBSSON LAMP

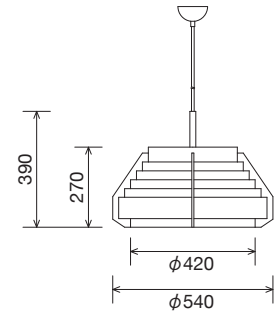

1.0kg FE205

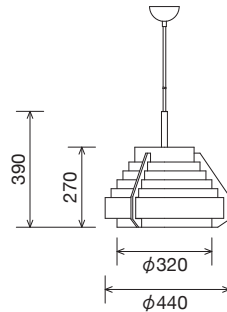

0.6kg FE206

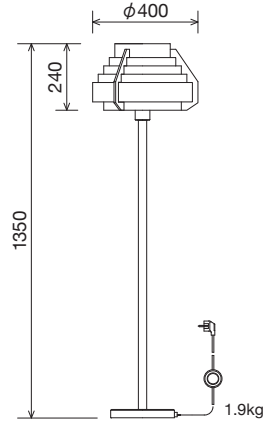

1.9kg

SUSPENSION

JAKOBSSON LAMP

CE 220V-240V
FE205 ϕ 540
E27 LED Bulb 13Wx1

PS 100V
E 323F-217 ϕ 540
E26 LED Bulb 100Wx3

SUSPENSION

JAKOBSSON LAMP

CE 220V-240V
FE206 ϕ 440
E27 LED Bulb 13Wx1

PS 100V
E 323F-218 ϕ 440
E26 LED Bulb 100Wx1

FLOOR

JAKOBSSON LAMP

CE 220V-240V
SE168
E27 LED Bulb 13Wx1

PS 100V
E 323S7338
E26 LED Bulb 100Wx1

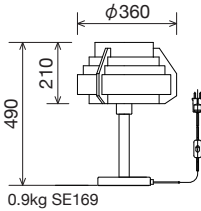

0.9kg SE169

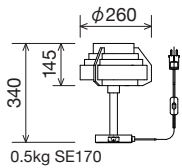

0.5kg SE170

TABLE

JAKOBSSON LAMP

CE 220V-240V
SE169 ϕ 360
E27 LED Bulb 8Wx1

PS 100V
E 323S7339 ϕ 360
E26 LED Bulb 60Wx1

TABLE

JAKOBSSON LAMP

CE 220V-240V
SE170 ϕ 260
E14 LED Bulb 6Wx1

PS 100V
E 323S2904 ϕ 260
E17 Incandescent lamp 60Wx1

K-SERIES

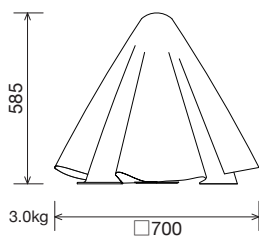

3.0kg \square 700

FLOOR

K-SERIES

CE 220V-240V
SE171
E27 LED Bulb 8Wx1

PS 100V
E 320S7473
E26 LED Bulb 60Wx1

TEAR DROP

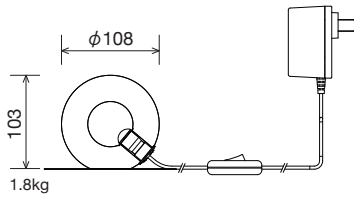

TABLE

TEAR DROP MINI LED

CE 100V-240V
SE172
LED module 2W

PS E 100V-240V
S7517
LED module 2W

CREA



SUSPENSION

CREA

CE 220V-240V
FE215 Ebony
FE216 Walnut
FE217 Oak
E14 LED Bulb 5Wx1

PS E 100V
320F-241 Ebony
320F-242 Walnut
320F-570 Oak
E17 LED Bulb 60Wx1

TWILIGHT

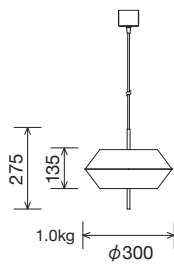
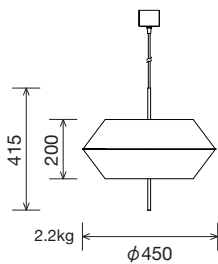

SUSPENSION

TWILIGHT

CE 220V-240V
FE221K ϕ 450
E14 LED Bulb 4.3Wx3

FE222K ϕ 300
G9 LED Bulb 2.6Wx3

PS E 100V
320F-543K ϕ 450
E17 LED Bulb 35W(LDF004D)x3

320P2951K ϕ 300
G9 Halogen lamp Clear 110V25Wx3

TABLE

TWILIGHT TABLE

CE 220V-240V
SE183K
G9 LED Bulb 2.6Wx3

PS E 100V
320S7530K
G9 Halogen lamp Clear 110V25Wx3

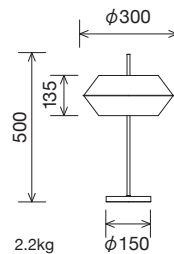

FACTS & FIGURES

SUI

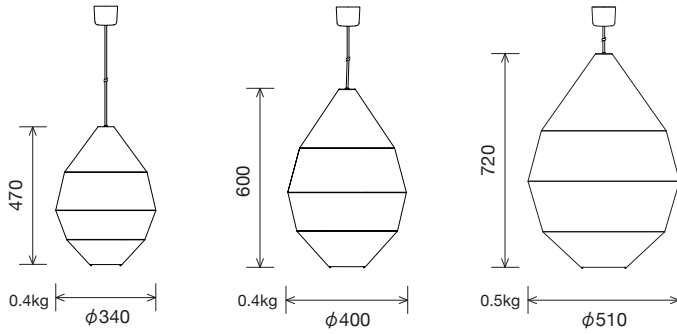

SUSPENSION

SUI

CE 220V-240V
FE210 ϕ 510
FE211 ϕ 400
FE212 ϕ 340
E27 LED Bulb 13Wx1

PS 100V
E 320F-529 ϕ 510
320F-530 ϕ 400
320F-531 ϕ 340
E26 LED Bulb 100Wx1

SYOKU

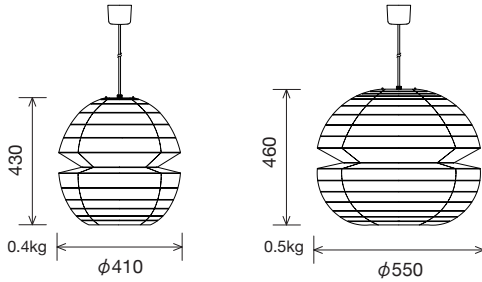

SUSPENSION

SYOKU

CE 220V-240V
FE213 ϕ 550
FE214 ϕ 410
E27 LED Bulb 13Wx1

PS 100V
E 320F-532 ϕ 550
320F-533 ϕ 410
E26 LED Bulb 100Wx1

RAI

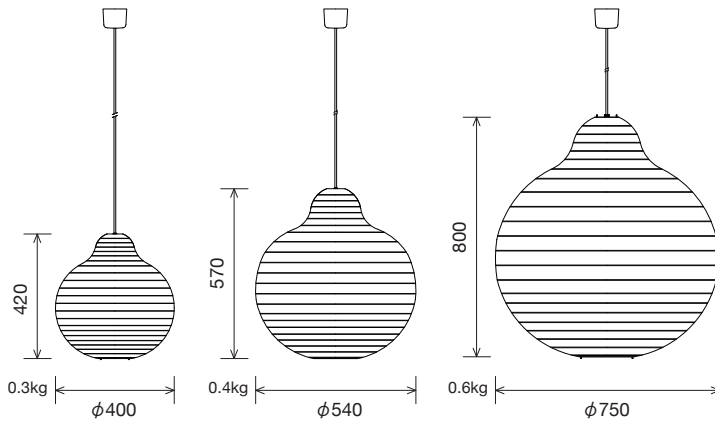

SUSPENSION

RAI

CE 220V-240V
FE218 ϕ 750
FE219 ϕ 540
FE220 ϕ 400
E27 LED Bulb 13Wx1

PS 100V
E 320F-571 ϕ 750
320F-572 ϕ 540
320F-573 ϕ 400
E26 LED Bulb 100Wx1

